

Complementary low voltage transistor

Features

- Products are pre-selected in DC current gain

Application

- General purpose

Description

These epitaxial planar transistors are mounted in the SOT-32 plastic package. They are designed for audio amplifiers and drivers utilizing complementary or quasi-complementary circuits. The NPN types are the BD135 and BD139, and the complementary PNP types are the BD136 and BD140.

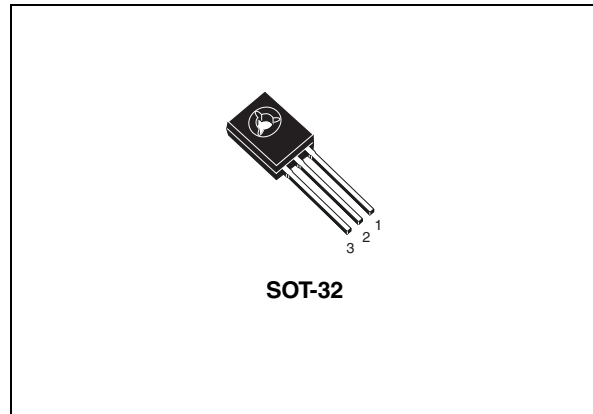

Figure 1. Internal schematic diagram

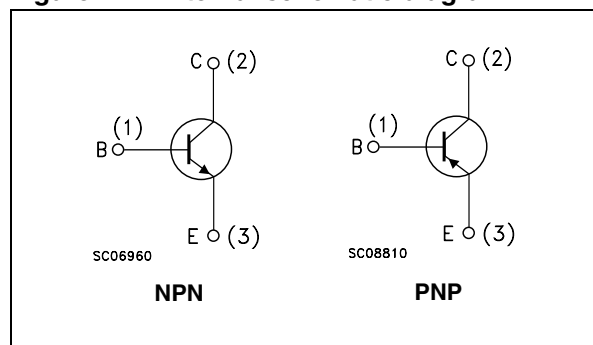

Table 1. Device summary

Order codes	Marking	Package	Packaging
BD135	BD135	SOT-32	Tube
BD135-16	BD135-16		
BD136	BD136		
BD136-16	BD136-16		
BD139	BD139		
BD139-10	BD139-10		
BD139-16	BD139-16		
BD140	BD140		
BD140-10	BD140-10		
BD140-16	BD140-16		

Contents

1	Electrical ratings	3
2	Electrical characteristics	4
	2.1 Electrical characteristics (curves)	5
3	Package mechanical data	6
4	Revision history	8

1 Electrical ratings

Table 2. Absolute maximum ratings

Symbol	Parameter	Value				Unit
		NPN		PNP		
		BD135	BD139	BD136	BD140	
V_{CBO}	Collector-base voltage ($I_E = 0$)	45	80	-45	-80	V
V_{CEO}	Collector-emitter voltage ($I_B = 0$)	45	80	-45	-80	V
V_{EBO}	Emitter-base voltage ($I_C = 0$)	5		-5		V
I_C	Collector current	1.5		-1.5		A
I_{CM}	Collector peak current	3		-3		A
I_B	Base current	0.5		-0.5		A
P_{TOT}	Total dissipation at $T_c \leq 25\text{ °C}$	12.5				W
P_{TOT}	Total dissipation at $T_{amb} \leq 25\text{ °C}$	1.25				W
T_{stg}	Storage temperature	-65 to 150				°C
T_j	Max. operating junction temperature	150				°C

Table 3. Thermal data

Symbol	Parameter	Max value	Unit
$R_{thj-case}$	Thermal resistance junction-case	10	°C/W
$R_{thj-amb}$	Thermal resistance junction-ambient	100	°C/W

2 Electrical characteristics

($T_{\text{case}} = 25\text{ °C}$ unless otherwise specified)

Table 4. On/off states

Symbol	Parameter	Polarity	Test conditions	Value			Unit
				Min.	Typ.	Max.	
I_{CBO}	Collector cut-off current ($I_{\text{E}}=0$)	NPN	$V_{\text{CB}} = 30\text{ V}$ $V_{\text{CB}} = 30\text{ V}, T_{\text{C}} = 125\text{ °C}$			0.1 10	μA μA
		PNP	$V_{\text{CB}} = -30\text{ V}$ $V_{\text{CB}} = -30\text{ V}, T_{\text{C}} = 125\text{ °C}$			-0.1 -10	μA μA
I_{EBO}	Emitter cut-off current ($I_{\text{C}}=0$)	NPN	$V_{\text{EB}} = 5\text{ V}$			10	μA
		PNP	$V_{\text{EB}} = -5\text{ V}$			-10	μA
$V_{\text{CEO(sus)}}^{(1)}$	Collector-emitter sustaining voltage ($I_{\text{B}}=0$)	NPN	$I_{\text{C}} = 30\text{ mA}$ BD135 BD139	45 80			V V
		PNP	$I_{\text{C}} = -30\text{ mA}$ BD136 BD140	-45 -80			V V
$V_{\text{CE(sat)}}^{(1)}$	Collector-emitter saturation voltage	NPN	$I_{\text{C}} = 0.5\text{ A}, I_{\text{B}} = 0.05\text{ A}$			0.5	V
		PNP	$I_{\text{C}} = -0.5\text{ A}, I_{\text{B}} = -0.05\text{ A}$			-0.5	V
$V_{\text{BE}}^{(1)}$	Base-emitter voltage	NPN	$I_{\text{C}} = 0.5\text{ A}, V_{\text{CE}} = 2\text{ V}$			1	V
		PNP	$I_{\text{C}} = -0.5\text{ A}, V_{\text{CE}} = -2\text{ V}$			-1	V
$h_{\text{FE}}^{(1)}$	DC current gain	NPN	$I_{\text{C}} = 5\text{ mA}, V_{\text{CE}} = 2\text{ V}$ $I_{\text{C}} = 150\text{ mA}, V_{\text{CE}} = 2\text{ V}$ $I_{\text{C}} = 0.5\text{ A}, V_{\text{CE}} = 2\text{ V}$	25 40 25		250	
		PNP	$I_{\text{C}} = -5\text{ mA}, V_{\text{CE}} = -2\text{ V}$ $I_{\text{C}} = -150\text{ mA}, V_{\text{CE}} = -2\text{ V}$ $I_{\text{C}} = -0.5\text{ A}, V_{\text{CE}} = -2\text{ V}$	25 40 25		250	
$h_{\text{FE}}^{(1)}$	h_{FE} groups	NPN	$I_{\text{C}} = 150\text{ mA}, V_{\text{CE}} = 2\text{ V}$ BD139-10 BD135-16/BD139-16	63 100		160 250	
		PNP	$I_{\text{C}} = -150\text{ mA}, V_{\text{CE}} = -2\text{ V}$ BD140-10 BD136-16/BD140-16	63 100		160 250	

1. Pulsed: pulse duration = 300 μs , duty cycle 1.5%

2.1 Electrical characteristics (curves)

Figure 2. Safe operating area

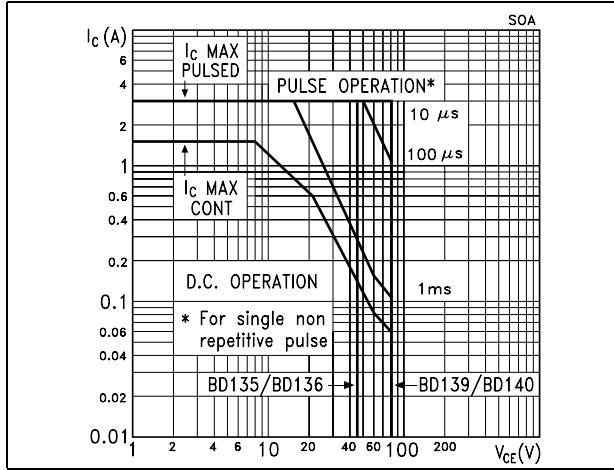
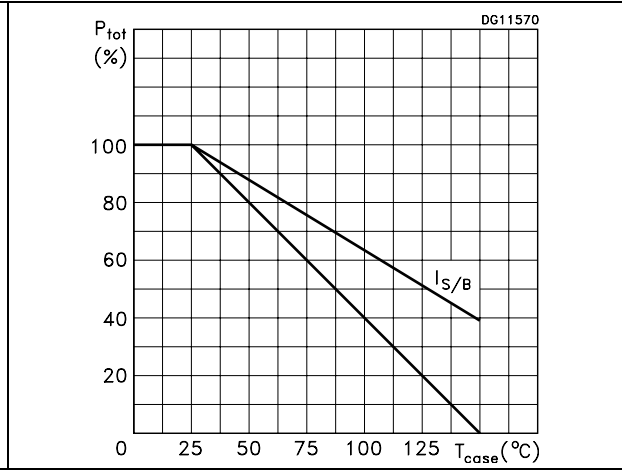

Figure 3. Derating



3 Package mechanical data

In order to meet environmental requirements, ST offers these devices in ECOPACK® packages. These packages have a lead-free second level interconnect. The category of second level interconnect is marked on the package and on the inner box label, in compliance with JEDEC Standard JESD97. The maximum ratings related to soldering conditions are also marked on the inner box label. ECOPACK is an ST trademark. ECOPACK specifications are available at: www.st.com

SOT-32 (TO-126) MECHANICAL DATA

DIM.	mm.		
	MIN.	TYP	MAX.
A	2.4		2.9
B	0.64		0.88
B1	0.39		0.63
D	10.5		11.05
E	7.4		7.8
e	2.04	2.29	2.54
e1	4.07	4.58	5.08
L	15.3		16
P	2.9		3.2
Q		3.8	
Q1	1		1.52
H2		2.15	
I		1.27	

